



Warsash Sailing Club



Sailing Instructions

Rooster Super South ITCA Traveller Saturday 14th & Sunday 15th September 2024

Saturday 14th September - HW 09.30

Sunday 15th September - HW 10.30

1 RULES

- 1.1 Racing will be governed by the ISAF Racing Rules of Sailing 2021-2024, the Prescriptions of the RYA, the Notice of Race, the Sailing Instructions issued for this event and the Class Rules. In the event of a conflict the Sailing Instructions shall take precedence.
- 1.2 Competitors should note that Warsash Sailing Club implements the RYA Racing Charter and that they will be required to undertake to sail in compliance with the Charter, which can be found at the front of the RYA rule book.
- 1.3 The Racing rules of Sailing will be changed as follows:
 - 1.3.1 RRS 35 changed to score boats finishing outside the time limit in their observed position on the course.
 - 1.3.2 RRS 40 changed so that Personal Flotation Devices shall be worn at all times while afloat.

2 NOTICES TO COMPETITORS

- 2.1 Notices to all competitors will be posted on the Event WhatsApp Group, any problems with WhatsApp will not be considered grounds for redress.
- 2.2 There will be a briefing by the Race Officer at 1000 on Saturday 14th September 2024 with a shorter update before launching at 0900 on the Sunday.

3 CHANGES TO SAILING INSTRUCTIONS

- 3.1 Any change to the sailing instructions will be posted before the briefing on the day it will take effect.

4 SIGNALS MADE ASHORE

- 4.1 Signals made ashore will be displayed on the Shore House Flag Staff.

5 SCHEDULE OF RACES

- 5.1 It is intended that there will be a maximum of 8 races for each fleet, with no more than 5 races per day.
- 5.2 When flag AP is displayed ashore, '1 minute' is replaced by 'not less than 60 minutes' in the race signal AP.
- 5.3 The first race will not start before 11:00 on the Saturday and not before 10:00 on the Sunday.

6 CLASS FLAGS

- 6.1 The Class Flag for 5.3 fleet will be Flag 'T' and for the 4.2 fleet Flag 'D'

7 RACING AREAS

- 7.1 The race area will be within Southampton Water/The Solent, in the vicinity of Coronation Buoy. These buoys are shown on the chart in Appendix C below.





Warsash Sailing Club



- 7.2 Competitors will be escorted to and from the race areas by RIBs.
- 7.3 Competitors are reminded that it is approximately 2 miles to the race area and that racing will start promptly.
- 8 THE COURSE**
- 8.1 The diagrams in Appendix A & B show the courses for the 4.2 & 5.3 fleets, including the approximate angles between legs, the order in which marks are to be passed, and the side on which each mark is to be left.
- 8.2 The number of upwind legs will be displayed on the Committee Boat prior to the commencement of each start sequence.
- 9 MARKS**
- 9.1 Mark 1, 2, 3, 4 and 5 will be black or orange inflatable buoys.
- 9.2 The Finish mark will be a small orange inflatable buoy. The start mark may also be in place when finishing.
- 10 THE START**
- 10.1 Races will be started by using RRS 26 (5, 4, 1 Go).
- 10.2 The start line will be between the mast displaying an orange flag on the committee boat at the starboard end of the line, and a dan buoy displaying an orange flag.
- 10.3 There will be a separate start for the 4.2 fleet. The intended start order will be the 5.3 fleet followed by the 4.2 fleet.
- 10.4 If there is a general recall for the 5.3 fleet it is intended to restart them before the 4.2 fleet.
- 10.5 A boat starting later than 4 minutes after her starting signal will be scored Did Not Start. This changes RRS A4 and A5.
- 11 CHANGE OF THE NEXT LEG OF THE COURSE**
- 11.1 To change the next leg of the course, the Race Committee will move the original mark (or the finishing line) to a new position.
- 11.2 Changes of the length of the leg or of less than 10 degrees will not be signalled. This changes RRS 33.
- 11.3 When Flag 'F' is displayed with repeated sound signals at Mark 1 boats shall proceed to the finish rounding marks 2, 3 and 4 to port. When it is displayed at Mark 3 boats shall proceed to the finish rounding mark 4 to port.
- 12 THE FINISH**
- 12.1 The finishing line will be between the mast displaying a blue flag on the committee boat and the finish mark.**
- 13 TIME LIMITS**
- 13.1 The intended duration of each race is approximately 35-40 minutes.
- 13.2 To expedite the series, and at the Race Committee's discretion, boats failing to finish within 10 or more minutes of the first boat may be awarded points according to their observed position on the course. The display of Flag 'W' with 5 sound signals will indicate that this SI applies. This changes Rule A.4.1.
- 14 COMMITTEE BOAT IDENTIFICATION**
- 14.1 The Committee Boat will be "Lobster" and will display a Warsash committee flag and club burgee.





Warsash Sailing Club



15 PROTESTS AND REQUESTS FOR REDRESS

- 15.1 A boat that intends to protest shall inform the Committee Boat immediately after finishing the race in which the incident occurred.
- 15.2 Protest forms are available in the main hall in Shore House. Protests shall be delivered there within the protest time limit.
- 15.3 The protest time limit is 30 minutes after the last boat of the protestor's fleet returns ashore. This changes RRS 61.3.
- 15.4 Notices will be posted within 30 minutes of the protest time limit of the last fleet ashore to inform competitors of hearings in which they are parties or named as witnesses. Hearings will be held at the earliest opportunity.
- 15.5 The exoneration penalty and RYA Arbitration procedure as described in the 'RYA Guidance – Rules Disputes' shall apply. The Exoneration Penalty shall be 30% with a minimum of 4 places.

16 SCORING

- 16.1 Points will be accrued to the helm named on the entry form not to the boat entered.
- 16.2 2 races are required to be completed to constitute a series.
 - a) When fewer than 4 races have been completed, a competitor's series score will be the total of their race scores
 - b) When 4 to 7 races have been completed, a competitor's score will be the total of her race scores excluding their worst score
 - c) When 8 races have been completed, a competitor's score will be the total of her race scores excluding their worst two scores

17 SAFETY REGULATIONS

- 17.1 Competing boats shall not go afloat until released by the Beachmaster.
- 17.2 Boats shall 'tally out' immediately before launching and 'tally in' immediately on returning ashore.
- 17.3 Failure to comply with this SI will result in a 5 point penalty in the race closest to the infringement, other boats will not be rescored. A boat will not be scored worse than a disqualified boat as a result of this penalty. This changes RRS 63.1.
- 17.4 Tallies will be issued and logged at time of launch. The tally board located in Shore House garden will close 15 minutes after the last boat returns ashore.
- 17.5 A boat that retires from a race shall notify the Race Committee as soon as possible and shall not leave the Race Area without the permission of the Race Committee. Boats returning ashore will be escorted.
- 17.6 Where the Race Committee considers that a boat or competitor is in difficulty it may instruct the boat or competitor to accept outside help, retire or sail ashore.

18 EQUIPMENT AND MEASUREMENT CHECKS

- 18.1 A boat or equipment may be inspected at any time for compliance with the class rules.





Warsash Sailing Club



19 TRASH DISPOSAL

19.1 Boats shall not drop trash in the dinghy park or into the water, all rubbish must be taken ashore by the sailors.

20 SUPPORT BOATS

20.1 Support Boats are only allowed with the prior approval of Warsash Sailing Club and drivers may be asked to show competence in driving such a boat of at least RYA PB2. Support Boats if allowed shall have VHF radio communication with Warsash Sailing Club and respective race support boats.

20.2 Unless instructed by the Race Committee, team leaders, coaches and other support personnel shall stay outside areas where boats are racing from the time of a preparatory signal until boats have finished or the Race Committee signals a postponement, general recall, or abandonment.

21 RADIO COMMUNICATION

21.1 A boat shall neither make radio transmissions while racing nor receive radio communications not available to all boats. This restriction also applies to mobile telephones.

22 PRIZES

22.1 Prizes will be awarded at the discretion of the organising authority.

23 RISK STATEMENT

23.1 Competitors are reminded of the Risk Statement in the NOR.

24 RIGHTS TO USE NAME AND LIKENESS

24.1 By participating in this event, competitors automatically grant to the organising authority and the event sponsors the right, in perpetuity, to make use and show, at their discretion, any photography, audio and video recording, and other reproductions of them made at the venue or on the water from the time of their arrival at the venue, until their departure, without compensation.





Warsash Sailing Club



Appendix A – Topper 5.3 Course

Using the diagram below, the Course will be:

For a single upwind race	For a 2 upwind race	For a 3 upwind race
Start Line	Start Line	Start Line
1 (port)	1 (port)	1 (port)
2 (port)	2 (port)	2 (port)
3 (port)	3 (port)	3 (port)
4 (port)	2 (port)	2 (port)
Finish Line	3 (port)	3 (port)
	4 (port)	2 (port)
	Finish Line	3 (port)
		4 (port)
		Finish Line

NOTE: The final upwind to the Committee Boat is excluded from the lap counting

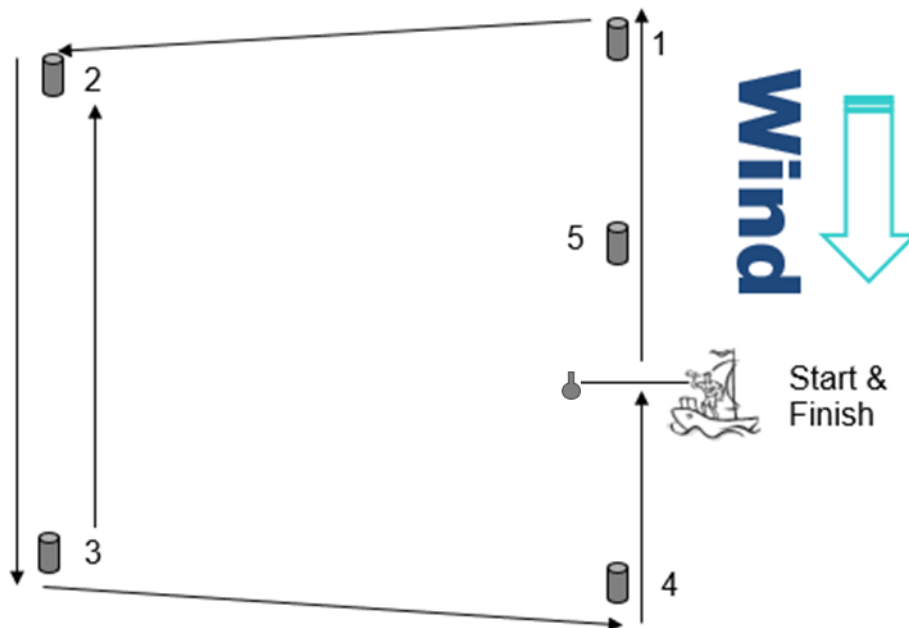



Warsash Sailing Club



Appendix B – Topper 4.2 Course

Using the diagram below, the Course will be:

For a single upwind race	For a 2 upwind race	For a 3 upwind race
Start Line	Start Line	Start Line
1 (port)	1 (port)	1 (port)
2 (port)	5(port)	5 (port)
3 (port)	1 (port)	1 (port)
4 (port)	2 (port)	5 (port)
Finish Line	3 (port)	1 (port)
	4 (port)	2 (port)
	Finish Line	3 (port)
		4 (port)
		Finish Line

NOTE: The final upwind to the Committee Boat is excluded from the lap counting

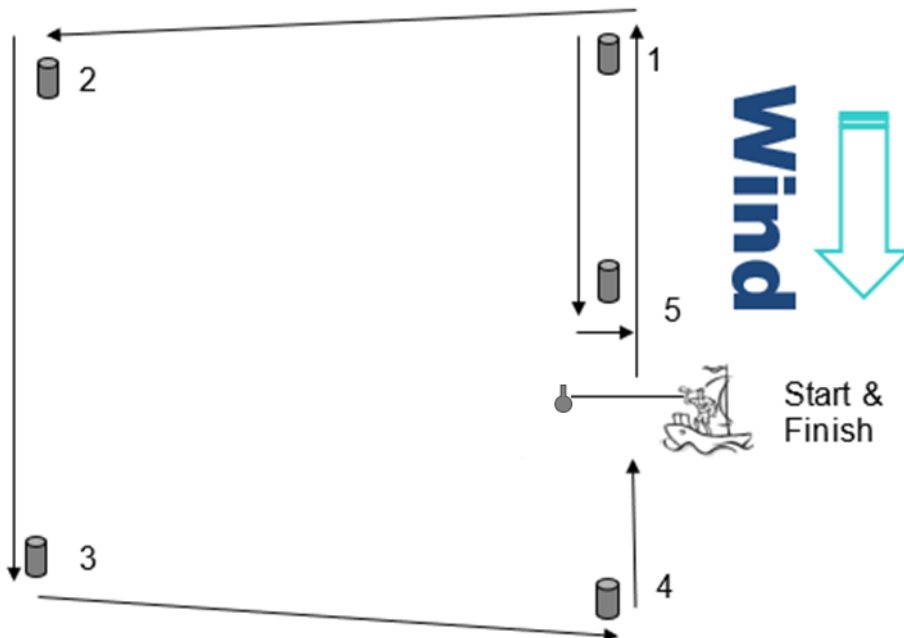



Warsash Sailing Club



Appendix C – Racing Area

